



+ USER GUIDE

MEXICO

HE15 HE18 HE24 HE30 HE36

When replacing any part on this appliance, use only spare parts that you can be assured conform to the safety and performance specification that we require. Do not use reconditioned or copy parts that have not been clearly authorised by Ideal.

For the very latest copy of literature for specification and maintenance practices visit our website www.idealboilers.com where you can download the relevant information in PDF format.

mexico HE15, HE18, HE24, HE30, HE36 (Natural Gas Only)

Destination Countries: GB, IE

HE15	G.C. Appliance No. 41-429-39
HE18	G.C. Appliance No. 41-429-65
HE24	G.C. Appliance No. 41-429-98
HE30	G.C. Appliance No. 41-429-99
HE36	G.C. Appliance No. 41-415-20

Introduction

The **mexico HE** is a floor standing, room sealed, condensing boiler featuring full sequence automatic spark ignition and fan assisted combustion.

Due to the very high efficiency of the boiler condensate is produced from the flue gases and this is drained to a suitable disposal point through the plastic waste pipe at the right lower rear of the boiler. A condensate 'plume' will also often be visible at the flue terminal.

Safety

Current Gas Safety (Installation & Use) Regulations or rules in force.

In your own interest, and that of safety, it is the law that this boiler must be installed by a Gas Safe Registered Engineer.

In IE the installation must be carried out by a Registered Gas Installer and installed in accordance with the current edition of I.S. 813 "domestic Gas Installations", the current Building Regulations and reference should be made to the current ETCI rules for electrical installation.

It is essential that the instructions in this booklet are strictly followed, for safe and economical operation of the boiler.

Electricity Supply

The appliance must be earthed.

Supply 230 V - 50 Hz. The fusing should be 3A.

This appliance is intended to be connected to the supply via a double-pole switch, having a 3mm contact separation in both poles, serving only the boiler and system controls. Alternatively, a 3-pin UNSWITCHED socket may be used.

Important Notes

- This appliance must not be operated without the casing correctly fitted and forming an adequate seal.
- If the boiler is installed in a compartment then the compartment MUST NOT be used for storage purposes.
- Under NO circumstances should any of the sealed components on this appliance be used incorrectly or tampered with.
- If it is known or suspected that a fault exists on the boiler then it MUST NOT BE USED until the fault has been corrected by a Gas Safe Registered Engineer or in IE a Registered Gas Installer.

- This appliance is not intended for use by persons (including children) with reduced physical, sensory or mental capabilities, or lack of experience and knowledge, unless they have been given supervision or instruction concerning use of the appliance by a person responsible for their safety.
- Children should be supervised to ensure that they do not play with the appliance.

In cases of repeated or continuous shutdown a Gas Safe Registered Engineer or in IE a Registered Gas Installer should be called to investigate and rectify the condition causing this and carry out an operational test after each intervention on the device. Only the manufacturers original parts should be used for replacement.

Minimum Clearances

Clearances of **20mm (3/4")** above, **5mm (1/4")** at the sides and **450mm (17 3/4")** at the front of the boiler casing must be allowed for servicing.

The minimum front clearance allowed when built into a cupboard is 5mm.

To light the boiler (Refer to Frame 1)

1. CHECK THAT THE ELECTRICITY SUPPLY TO THE BOILER IS OFF.
2. Set the mains on/off switch (A) to off and the CH thermostat knob (B) to maximum.
3. Switch on the electricity supply to the boiler and check that all external controls, e.g. programmer, room stat, etc. are on.
4. Set the mains on/off switch to ON.

The boiler will commence the ignition sequence, supplying heat to the system when required.

Operation

In normal operation the control unit display (E) will show the codes:

O - Standby (no demand for heat)

C - CH or DHW being supplied

P - Boiler frost protection (boiler will fire when temperature is less than 3°C)

During *ignition* the LED (D) will flash.

During *normal running* the LED will remain illuminated.

Note. *If the boiler fails to light after 3 attempts the fault code 'L' 'F' will be displayed.*

Press and hold the reset button (C) for 2 seconds then release. The boiler will repeat the ignition sequence. If the boiler fails to light consult a Gas Safe Registered Engineer or in IE a Registered Gas Installer.

All Gas Safe Registered Engineers carry a Gas Safe Register ID card, and have a registration number. Both should be recorded in the **Benchmark** Commissioning Checklist. You can check your installer by calling Gas Safe Register direct on 0800 4085500.

Ideal Boilers is a member of the Benchmark scheme and fully supports the aims of the programme. Benchmark has been introduced to improve the standards of installation and commissioning of central heating systems in the UK and to encourage the regular servicing of all central heating systems to ensure safety and efficiency.

THE BENCHMARK SERVICE INTERVAL RECORD MUST BE COMPLETED AFTER EACH SERVICE



Control of water temperature

The boiler controls the central heating radiator temperature to a maximum of 82°C, adjustable via the CH thermostat knob (B).

Approx. CH flow temperatures for the boiler thermostat settings are:

Knob Setting	Flow Temperature	
	°C	°F
Minimum	30	86
Maximum	82	180

To shut down the boiler

1. For short periods

Set the mains on/off switch (A) to OFF.

2. For longer periods

Set the mains on/off switch (A) to OFF. Switch the electricity supply to OFF. For longer periods the entire system should be drained, including the domestic hot water supply.

To relight the boiler

Repeat the procedure detailed in 'To light the boiler'.

Frost Protection

If no frost protection is provided and frost is likely during a short absence from home leave the heating controls (if fitted) at a reduced temperature setting.

For longer periods the entire system should be drained.

If the system includes a frost thermostat then, during cold weather, the boiler should be turned OFF at the time switch (if fitted) ONLY. The mains supply should be left switched ON, with the boiler thermostat left in the normal running position.

Boiler Overheat Thermostat

This thermostat will shut down the boiler in the event of overheating. Should this occur a fault code 'L-R' will be displayed. Press the reset button (C) and the boiler will relight. If the fault recurs turn off the boiler and consult a Gas Safe Registered Engineer or in IE a Registered Gas Installer.

Flame failure

Should this occur a fault code 'L-F' will be displayed. Press the reset button and the boiler will relight. If the fault recurs, turn off the boiler and consult a Gas Safe Registered Engineer or in IE a Registered Gas Installer.

Condensate Drain

This appliance is fitted with a siphonic condensate trap system that reduces the risk of the appliance condensate from freezing. However should the condensate pipe to this appliance freeze, please follow these instructions:

- If you do not feel competent to carry out the defrosting instructions below please call your local Gas Safe Registered installer for assistance.
- If you do feel competent to carry out the following instructions please do so with care when handling hot utensils. Do not attempt to thaw pipework above ground level.

If this appliance develops a blockage in its condensate pipe, the condensate will build up to a point where it will make a gurgling noise prior to locking out an "L2" fault code. If the appliance is reset it will make a gurgling noise prior to it locking out on a failed ignition "L2" code.

To unblock a frozen condensate pipe;

- Follow the routing of the plastic pipe from its exit point on the appliance, through its route to its termination point.

Locate the frozen blockage. It is likely that the pipe is frozen at the most exposed point external to the building or where there is some obstruction to flow. This could be at the open end of the pipe, at a bend or elbow, or where there is a dip in the pipe in which condensate can collect. The location of the blockage should be identified as closely as possible before taking further action.

- Apply a hot water bottle, microwaveable heat pack or a warm damp cloth to the frozen blockage area. Several applications may have to be made before it fully defrosts. Warm water can also be poured onto the pipe from a watering can or similar. DO NOT use boiling water.
- Caution when using warm water as this may freeze and cause other localised hazards.
- Once the blockage is removed and the condensate can flow freely, reset the appliance (Refer to "To Light the boiler")
- If the appliance fails to ignite, call your Gas Safe Registered engineer.

Preventative solutions

During cold weather, set the boiler stat to maximum, (Must return to original setting once cold spell is over)

Place the heating on continuous and turn the room stat down to 15°C overnight or when unoccupied. (Return to normal after cold spell).

1 BOILER CONTROLS

Legend

- A Boiler on/off switch
- B CH thermostat knob
- C Reset button
- D LED
- E Display

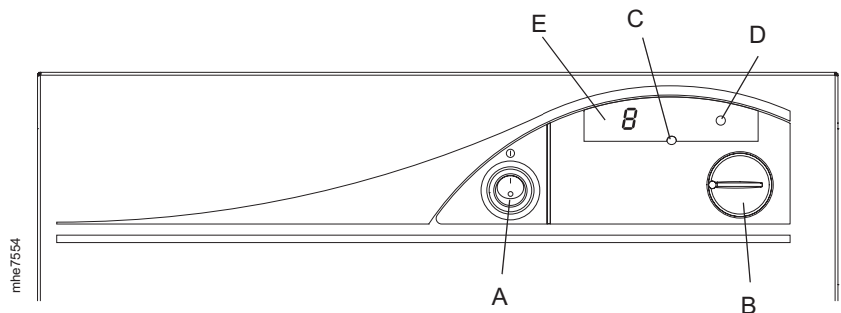

CAUTION. To avoid the possibility of injury during the installation, servicing or cleaning of this appliance care should be taken when handling edges of sheet steel components.

Escape of gas

Should a gas leak or fault be suspected contact your local gas supplier without delay.

Do NOT search for gas leaks with a naked flame.

Cleaning

For normal cleaning simply dust with a dry cloth.

To remove stubborn marks and stains use a damp cloth and mild detergent.

DO NOT use abrasive cleaning materials.

Maintenance

The appliance should be serviced at least once a year by a Gas SAfe Registered Engineer or in IE a Registered Gas Installer.

POINTS FOR THE BOILER USER

Note. In line with our current warranty policy we would ask that you check through the following guide to identify any problems external to the boiler prior to requesting a service engineers visit. Should the problem be found to be other than with the appliance we reserve the right to levy a charge for the visit, or for any pre-arranged visit where access is not gained by the engineer.

TROUBLESHOOTING - TYPICAL NON PRODUCT FAULTS

Problem	Solution
Boiler is not working for central heating or hot water.	<ul style="list-style-type: none">• Check there is power to the boiler – switch (A) in the ON position and 'D' displayed on the controls.• If 'D' not displayed then not a boiler fault – contact your installer/service company.• Check external programmer is set to an 'ON' period and the relevant function selected i.e. central heating or domestic hot water. Test by overriding the programmer by setting to 'continuous'.• Check room thermostat for central heating or the cylinder thermostat for domestic hot water, are set at the required temperature. To test operation of either thermostat turn fully up. If no response contact your installer.
Boiler is not working for central heating or hot water but attempts to fire by going through 3 ignition attempts. Display shows 'L:F' (flashing).	<ul style="list-style-type: none">• Press reset button (C) for 2 seconds to repeat ignition sequence.• Check gas supply (try another appliance – cooker/fire etc.) – If no gas supply then not a boiler fault – contact gas supplier.• Check condensate pipe is not blocked or frozen. If blocked, clear blockage – if not possible to check contact your installer.
Boiler is not working for central heating or hot water and the display shows 'L:R' (flashing).	<ul style="list-style-type: none">• Press reset button (C) for 2 seconds, the boiler should then re-light. If fault recurs this indicates an overheat condition. The boiler should be turned off and your installer contacted.• Check if ALL radiators have thermostatic radiator valves fitted. If they have contact your installer.
Boiler is not working for central heating or hot water and the display shows 'H:R' (flashing).	<ul style="list-style-type: none">• Check if ALL radiators have thermostatic radiator valves fitted. If they have contact your installer.